



OPTIMISED CAR OR VAN ROOF TRANSPORT

Car-topping your Airborn is often preferred for improved driving performance and convenience.

Recommended Setup

For safe and efficient transport, we recommend the following arrangement:

- Position the boat upside down to improve stability while driving
- The rig, launching trolley, and foils should be stored in dedicated travel bags
- Secure the complete setup to roof crossbars using appropriate straps

Our recommended configuration is based on high-quality solutions from the Thule range.

Thule equipment can be ordered directly from suppliers. A specific Airborn Kit is available, including all necessary protections, slings, and travel bags ready for immediate use.

RECOMMENDED THULE EQUIPMENT

Thule is recommended for transporting the Airborn. The Evo Pro range offers a variety of accessories designed to securely hold the boat in position and assist with side loading or loading onto a van.

EQUIPMENT FOR CAR

Qty	Item
4	Thule load stopper 314
2	Thule ProBar Evo (minimum length 1.75m)
4	Thule mounting Evo feet

ADDITIONAL EQUIPMENT FOR VAN

Qty	Item
1	Thule Roller XT M
1	Thule ProBar Evo (minimum length 1.75m)
2	Thule mounting Evo feet

Typical total cost for a car setup: €560

Typical total cost for a van setup (including rear bar and roller): €910

The equipment and setup described above are provided as recommendations only. Independent due diligence should be carried out, and all components should be purchased directly from dealerships. Please ensure compliance with all applicable local driving laws and regulations prior to purchase and use, as requirements may vary by region.

AIRBORN CAR-TOP KIT CONTENT

In addition to the recommended transport equipment, a kit with accessories and storage bags is available for order on our website. These bags are specifically designed for the Airborn, with integrated fibreglass structure, durable heavy-duty PVC fabric, and reinforced attachment points to securely fasten equipment to the boat. Straps and protective foam elements are also included. Trolley wheels, as well as loose ropes and blocks, should be stored separately inside the vehicle.

Qty	Item
4	Boat support foam pads, finished in sewn black protective fabric for surface protection
2	Heavy-duty attachment straps with stainless steel eyes, configured for a 2:1 tensioning system, and integrated buckles for mast and foil bags
4	Strap protection pads, finished in sewn black protective fabric, designed to fit securely around load straps
1	Mast, boom and launching trolley bag, with internal fibreglass structure, dividers, four stainless steel pad eyes, and buckle attachments for the foil bag
1	Foil bag, with internal fibreglass reinforcement, EVA foam inserts for secure foil storage, buckle attachments, and a zipped tool pocket

Cost of kit with bags and accessories: €1470

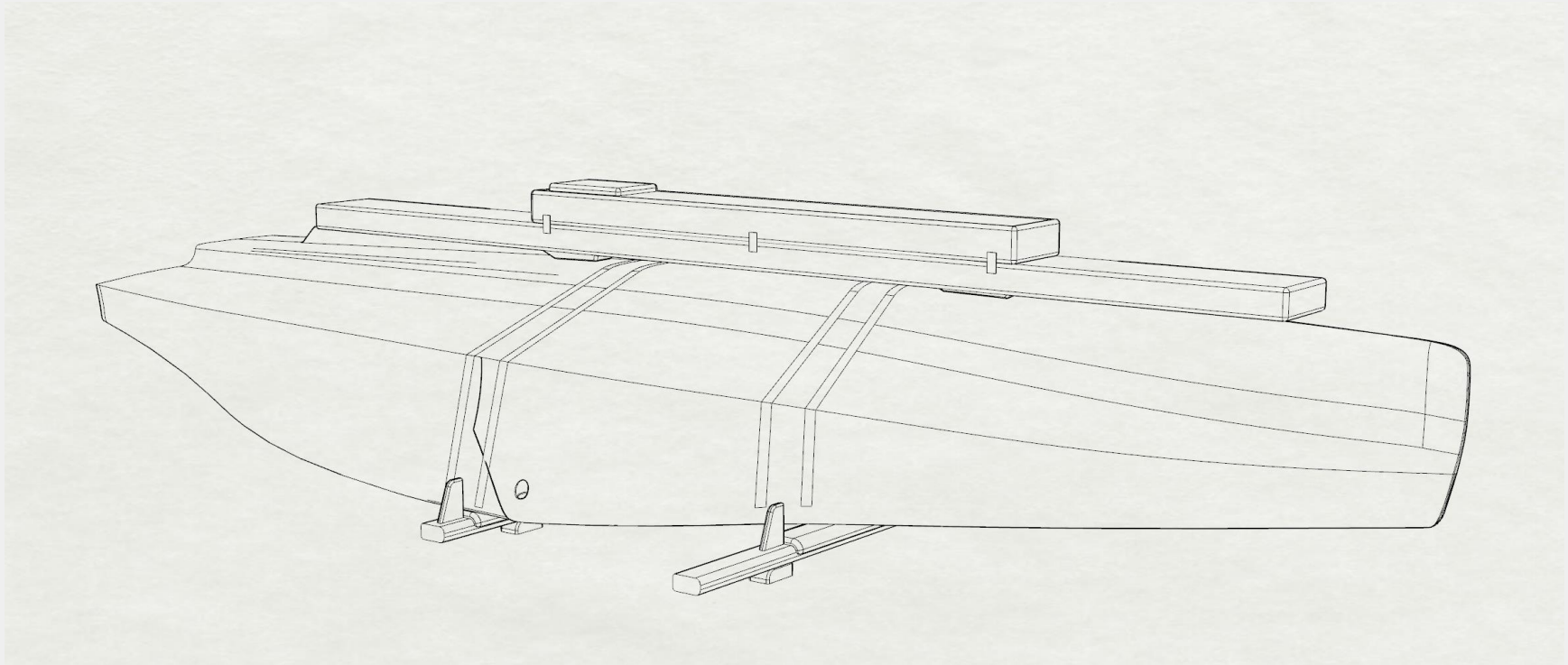

Recommended arrangement with the boat upside down for stability.
Cross bars, mast and foils bags which can be secured to the straps with cross bracing.

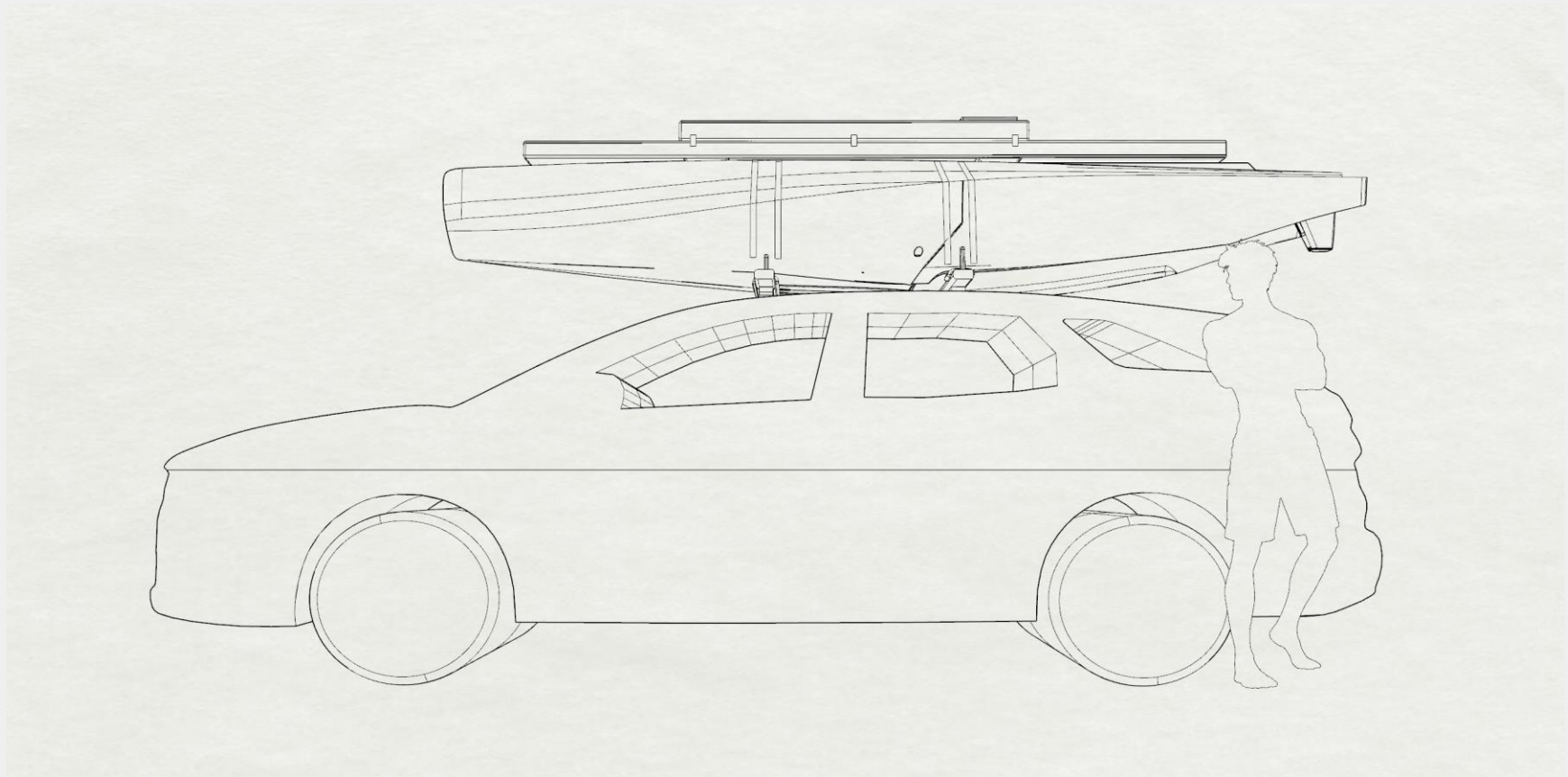

Arrangement with car.

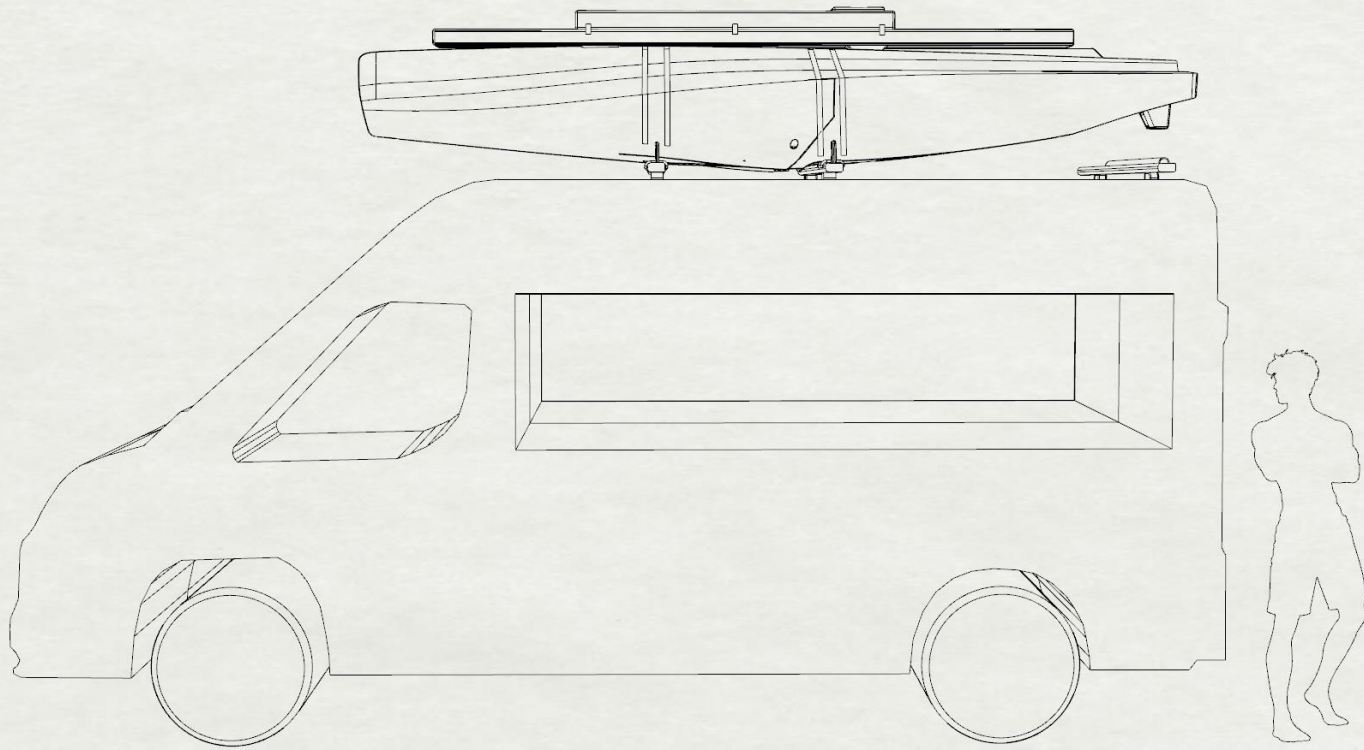

Arrangement with van. The aft roller can simplify the maneuver for 2 people after some protection is added to the boat.