



THE 650PRO

IT IS NOT A DREAM, IT IS HAPPENING. NOW.

Thomas Tison Yacht design is now ready to start the construction of the 650PRO. The boat is a Mini 650 with foils inspired by the Vendee Globe and the America's Cup. The 650PRO is designed for the challenges of today's offshore racing scene. On top of technical progress, the vision is to start a new racing circuit, for skippers promoting a new and better world. Skippers, sponsors, sailing clubs, this project is for you.

THE BOAT

The only platform to master foiling offshore

The 650PRO is one of a kind. It is the only boat offering skippers the opportunity to master foiling offshore, to take part in the Mini Transat and to prepare for the next Vendee Globe. The scow hull shape makes for a stable boat and the foils can be fully retracted when foiling is not possible, leaving a clean hull shape. The rig has been studied and designed to facilitate stable foiling while reducing physical demands on the skipper.

Some of the best yards, a world class design team and the one design class rules combine to make this project an asset for a 2 or 4 years campaign.

In the spirit of the Mini 6.50 class association

The 650Pro circuit is planned to complement the Classe Mini regattas, and respecting the spirit of the Protos : technical innovation, an open minded spirit, a sailing program which fosters good seamanship and controlled costs.

A project inspired by nature

This project follows in the footsteps of an earlier design whose aim was to develop new and innovative construction methods using Bionic principles. The one design construction also reduces the use of moulds which results in less material wastage.

A DEDICATED CIRCUIT

Events for skippers and sponsors

Discussing with yards and sailors, it became clear that a dedicated circuit was needed for new talents to rise. Talents that would be the first to master foiling offshore.

We are currently putting together a proposal for regattas in 2022 and 2023. The vision is to create an international circuit that would increase the value proposition for sponsors, while growing the relevance of our sport in today's world. The program would extend from the Med to the Atlantic and include existing prestigious regattas.

A circuit about progress

We believe all forms of progress are at the service of society at large. The proposal is for the future circuit to be thought for skippers and sponsors to communicate about all the solutions for a future, better world.

Towards the 2023 Mini Transat

The schedule is to start building the boats in 2021, the circuit in 2022 and taking part in the 2023 Mini Transat. Discussions are ongoing with skippers who look for an alternative to Class40s, Figaro 3, after a first Mini Transat, or after sailing on high performance skiffs and catamarans.

The design is presented on Instagram, and a proposal race program will be revealed in February.

More information at www.thomastison.com



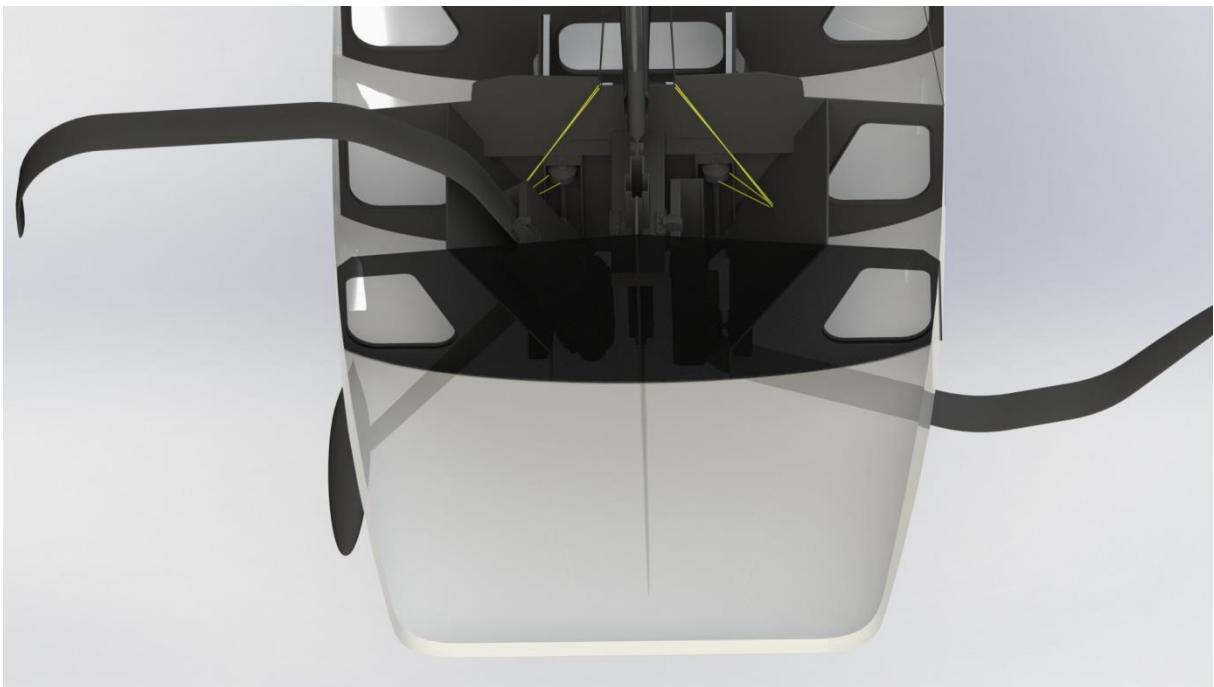

THOMAS TISON YACHT DESIGN AND ENGINEERING SARL
1 RUE D'ESTIENNE D'ORVES 56100 LORIENT
SIRET: 82960917100022 – INFO@THOMASTISON.COM – +33(0)783558797

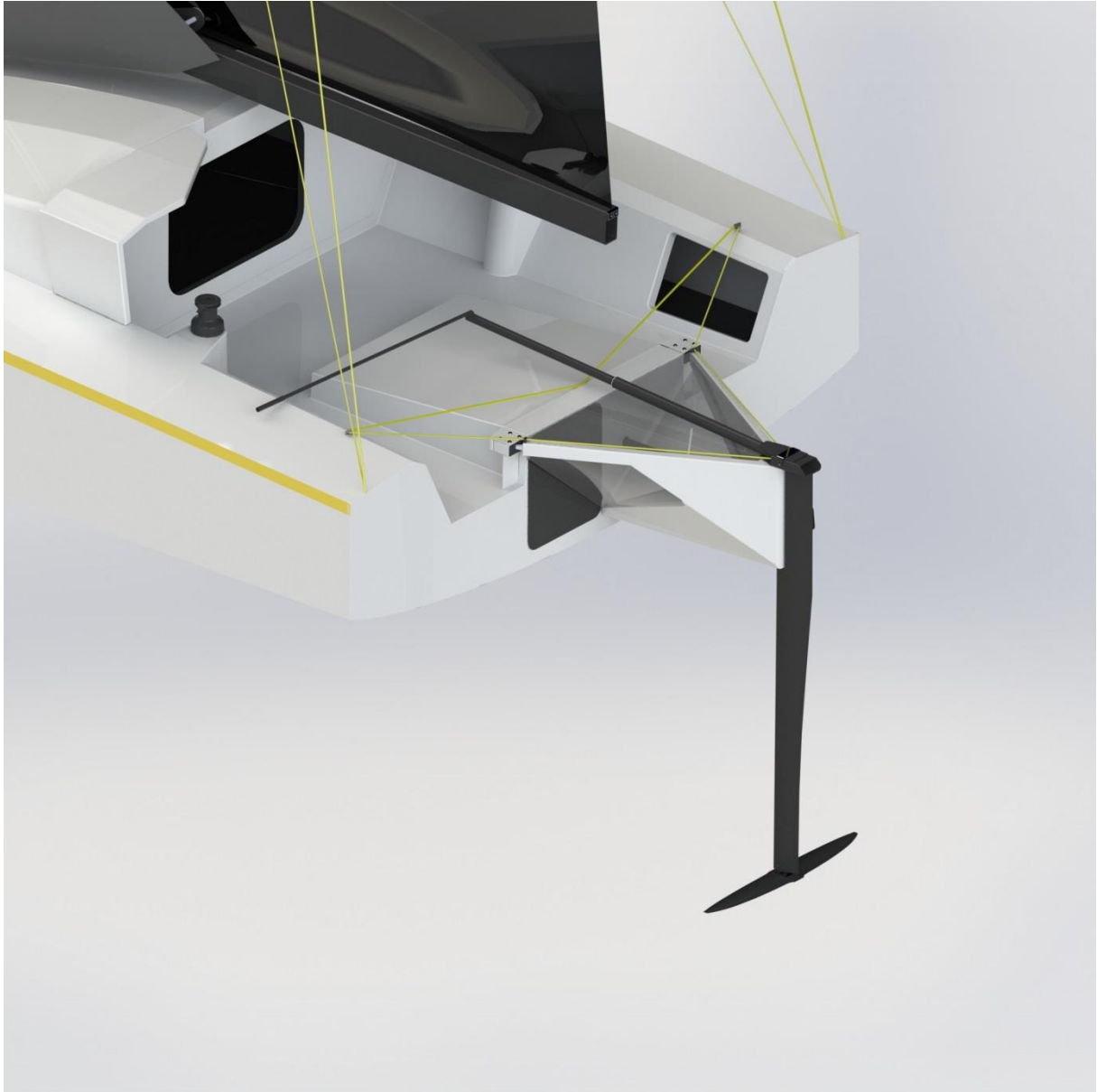

THOMAS TISON YACHT DESIGN AND ENGINEERING SARL
1 RUE D'ESTIENNE D'ORVES 56100 LORIENT
SIRET: 82960917100022 – INFO@THOMASTISON.COM – +33(0)783558797